

Bridging Science & Applications
From Earth to Space - and back

Earth
Space
&
Future

Kayser-Threde GmbH

Space

Industrial Applications

TET-1 Payload N6 Sensorbussystem

2nd TET Customer Day, July 5, 2010

Christoph Tiefenbeck

Kayser-Threde, Munich

Motivation: Sensor bus network for satellites

- + Reduction of mass
- + More flexibility regarding design and integration
- + Simplified assembly, integration und test procedures

Current ESA-activities:

- Evolving ECSS standard for transducer busses
- Standardization by extension/update of existing ECSS-E50-14

Kayser Threde:

- Several studies on sensor bus networks conducted
- Upcoming sensorbus network activities for SmallGeo platform
- On-orbit verification onboard TET-1: “N6 Sensorbussystem”

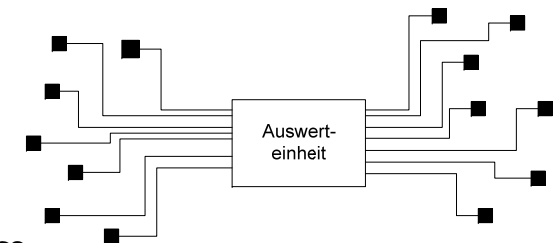
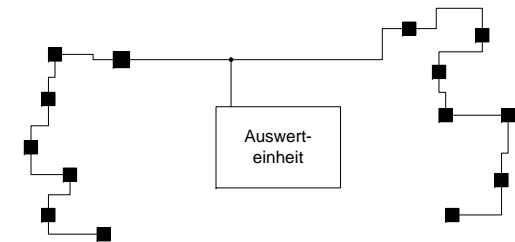

N6 Sensorbussystem 1/2

- N6-Box: power-supply, monitoring-functionality, data-acquisition and -processing unit
- 30 sensors distributed in TET-payload compartement
- One-wire standard by Maxim/Dallas for sensor network

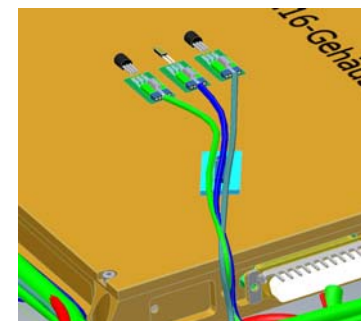
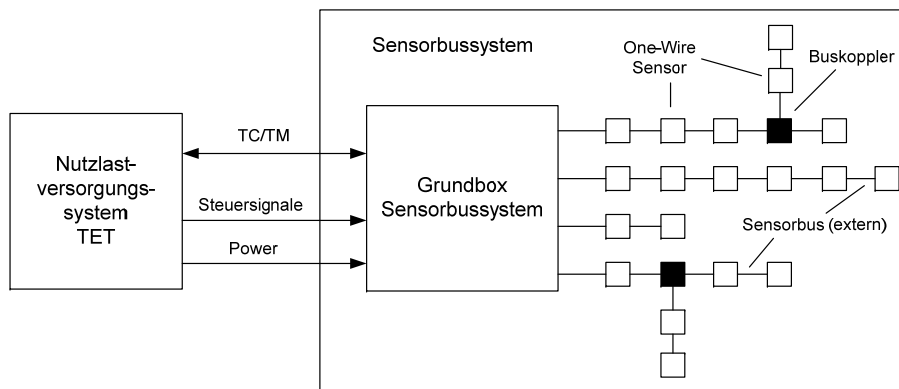
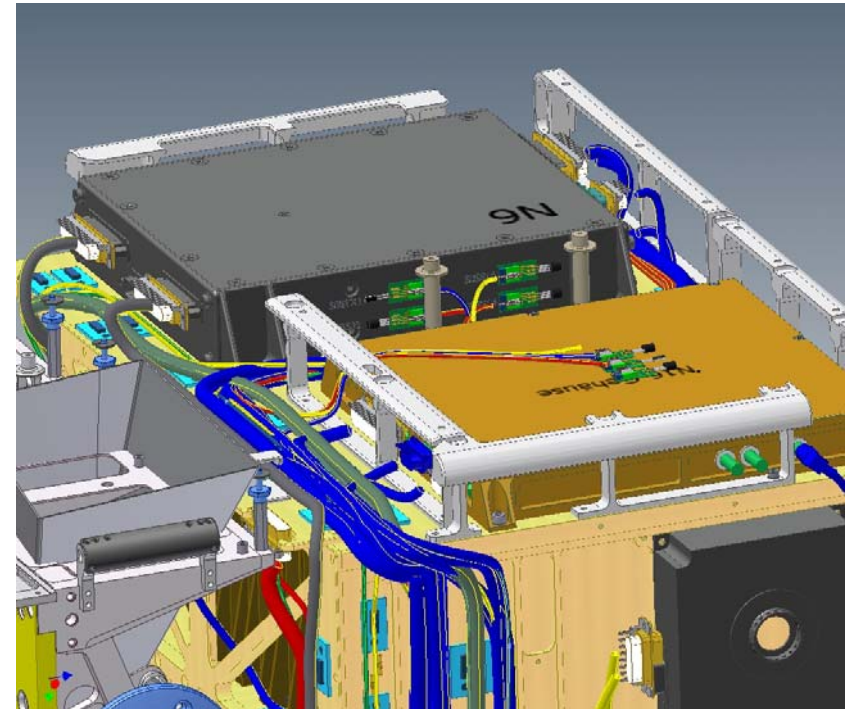

N6 Sensorbussystem 2/2

- **Module Sensorbussystem**

- Power supply (DC/DC-converter, EMI-filtering)
- 3 redundant experiment microcontrollers
- SEL-protection circuitry
- 4 redundant One-Wire busses



- **One-Wire Standard**

- Serial communication, half-duplex, 15 KBit/s or 111 KBit/s
- Single line (+ GND) for data- and power-transfer
- Unique device ID, CRC- failure detection
- Devices with memory-, digital-, analog-, and mixed-signal functions available

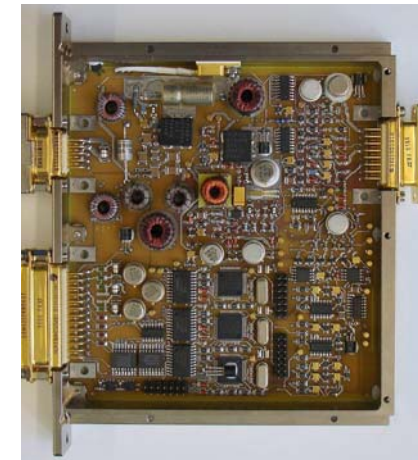
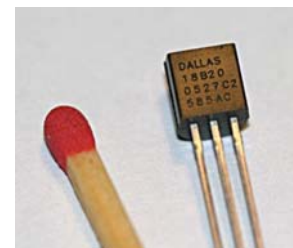

N6 Electronic Load for Experiments N2 and N8

- I-V characterisation of solar-cells
- Programmable constant current sink
- 0 – 1020mA, two ranges
- Inputs for 2x 6 cells
- Sequencing and analog-signal acquisition performed by TET NVS

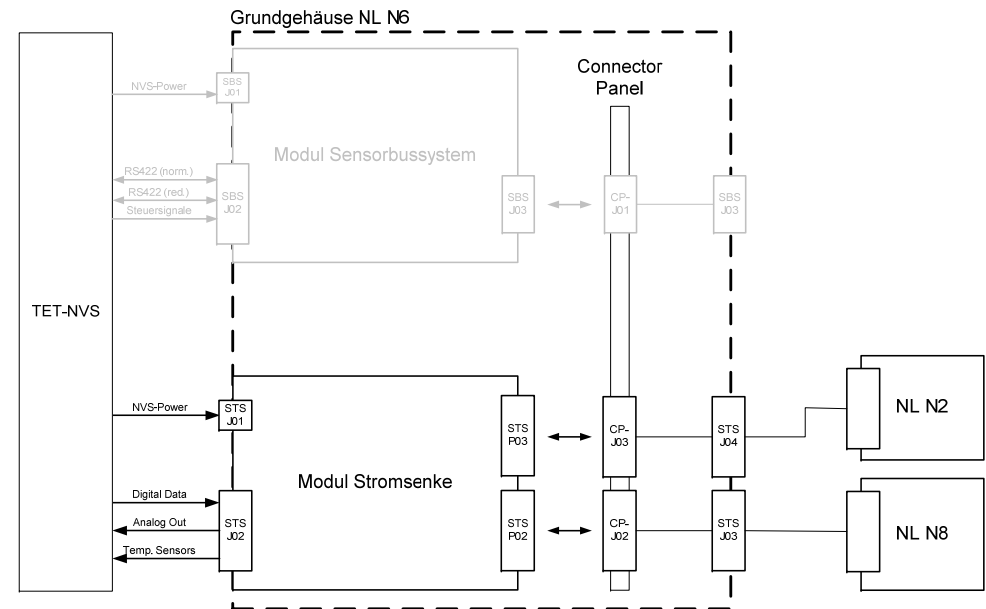
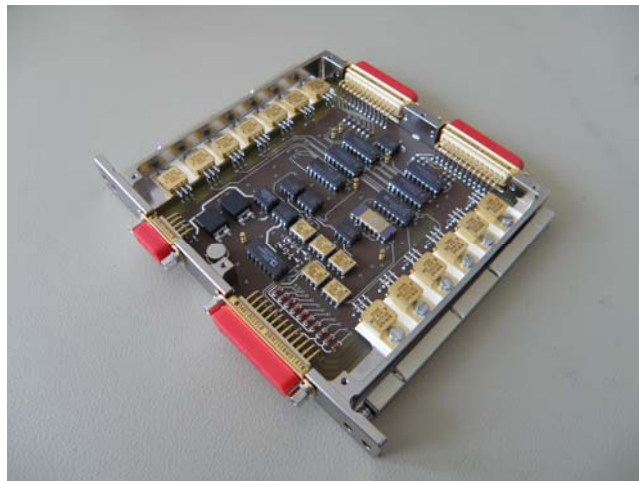

Tests and EGSE Software

- Qualification tests completed: Thermal-, EMC- and Functional-Tests
- Additional endurance tests
- Upcoming On-orbit performance tests

- Software for Data-evaluation

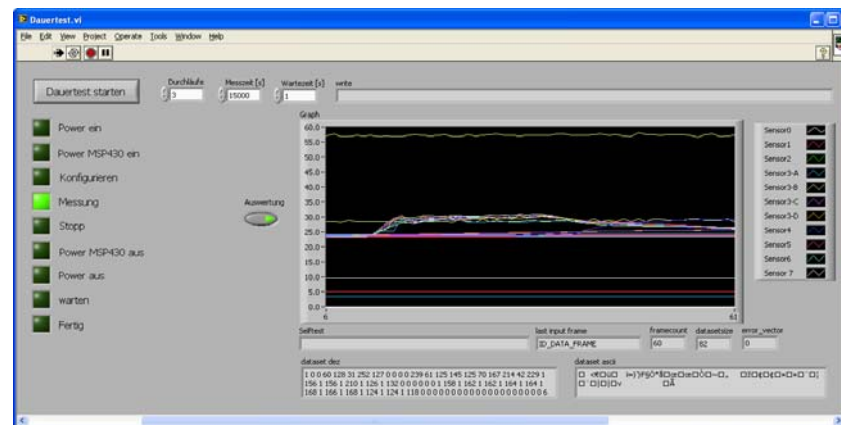
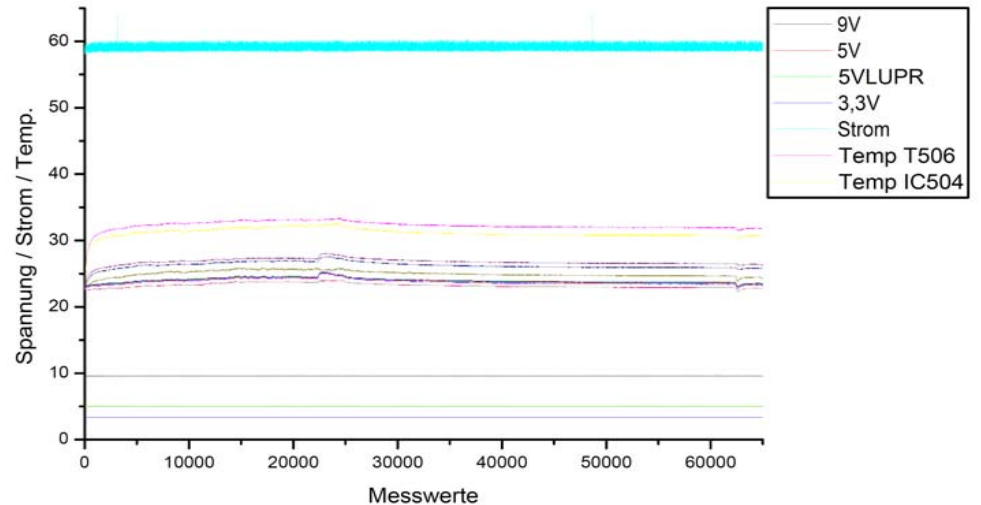

Thank you very much for your attention!