

TET-1

A GERMAN MICROSATELLITE FOR ON-ORBIT-VERIFICATION

Stefan Föckersperger⁽¹⁾, Klaus Lattner⁽¹⁾, Clemens Kaiser⁽¹⁾, Silke Eckert⁽²⁾, Wolfgang Bärwald⁽²⁾,
Swen Ritzmann⁽²⁾, Peter Mühlbauer⁽³⁾, Michael Turk⁽⁴⁾, Philipp Willemsen⁽⁴⁾.

⁽¹⁾ *Kayser-Threde GmbH, Wolfratshauser Straße 48, 81379 München, Germany,
Email: stefan.foeckersperger@kayser-threde.com*

⁽²⁾ *Astro- und Feinwerktechnik GmbH, Albert-Einstein-Straße 12, 12489 Berlin, Germany,
Email: s.eckert@astrofein.com*

*Deutsches Zentrum für Luft- und Raumfahrt e.V. (DLR), Rutherfordstr. 2, 12489 Berlin
E-Mail: wolfgang.baerwald@dlr.de*

⁽³⁾ *Deutsches Zentrum für Luft- und Raumfahrt e.V. (DLR), 82234 Weßling, Germany,
Email: peter.muehlbauer@dlr.de*

⁽⁴⁾ *DLR Space Agency, Königswinterer Straße 522-524, 53227 Bonn, Germany,
E-Mail: michael.turk@dlr.de*

ABSTRACT

Due to the high safety standards in the space industry every new product must go through a verification process before qualifying for operation in a space system. Within the verification process the payload undergoes a series of tests which prove that it is in accordance with mission requirements in terms of function, reliability and safety. Important verification components are the qualification for use on the ground as well as the On-Orbit Verification (OOV), i.e. proof that the product is suitable for use under virtual space conditions (on-orbit). Here it is demonstrated that the product functions under conditions which cannot or can only be partially simulated on the ground.

The OOV-Program of the DLR serves to bridge the gap between the product tested and qualified on the ground and the utilization of the product in space. Due to regular and short-term availability of flight opportunities industry and research facilities can verify their latest products under space conditions and demonstrate their reliability and marketability.

The Technologie-Erprobungs-Träger TET (Technology Experiments Carrier) comprises the core elements of the OOV Program. A programmatic requirement of the OOV Program is that a satellite bus already verified in orbit be used in the first segment of the program. An analysis of suitable satellite buses showed that a realization of the TET satellite bus based on the BIRD satellite bus fulfilled the programmatic requirements best.

Kayser-Threde was selected by DLR as Prime Contractor to perform the project together with its major subcontractors Astro- und Feinwerktechnik, Berlin for

the platform development and DLR-GSOC for the ground segment development. TET is now designed to be a modular and flexible micro-satellite for any orbit between 450 and 850 km altitude and inclination between 53° and SSO. With an overall mass of 120 kg TET is able to accommodate experiments of up to 50 kg. A multipurpose payload supply system under Kayser-Threde responsibility provides the necessary interfaces to the experiments. The first TET mission is scheduled for mid of 2010. TET will be launched as piggy-back payload on any available launcher worldwide to reduce launch cost and provide maximum flexibility. Finally, TET will provide all services required by the experimenters for a one year mission operation to perform a successful OOV-mission with its technology experiments leading to an efficient access to space for German industry and institutions.

1. BACKGROUND

The goal of the OOV (On-Orbit-Verification)-Program is to qualify new technological solutions for their application in space projects. It focuses on the in-flight demonstration and verification of highly advanced technologies. The core element of the program is the micro-satellite TET (Technology Experiment Carrier) as a platform for the verification flight.

1.1 The need for on-orbit verification

It is necessary to validate new, unproved techniques and technologies before using them in advanced missions. The OOV-Program fills the gap between a technology which has been qualified on the ground and its application in space. In order to support German industry and research institutes, the German Space Agency provides flight opportunities to qualify in-flight

new technological solutions in all areas of space craft technology such as power generation and storage, propulsion, guidance, navigation and control.

The first part of the program is scheduled for the years 2005-2012. The overall budget of the program within this time span is about 34 M€ The program is conducted in cooperation with DLR Space Research (PD-W).

1.2. Flight opportunities

Flight opportunities for technology demonstration and verification should ideally be provided on a regular basis, independent, cost efficient and safe. A market survey of German industries' and institutes' technologies has shown that about 75 % of the experiments can be verified using a micro-satellite.

The OOV-Program is thus structured into two main parts with respect to the flight opportunities offered. The first comprises the micro-satellites TET with a planned flight every two years. For payloads which do not fit on TET, the DLR Space Agency cooperates with national and international partners in order to provide flight opportunities on other carriers.

2. MISSION OVERVIEW

The whole mission is designed based on the main mission requirements shown in Tab.1.

Table 1: TET main mission requirements

Mission duration: 1 month LEOP incl. Satellite commissioning and 12 months mission operations
Type of Orbit: circular
Orbit height: between 450 – 850 km
Orbit inclination: 53° to sun-synchronous
Piggy-Back Launch
Reliability requirement: 0.9 (for platform and payload support system)
Ground stations: Weilheim for TT&C, Neustrelitz for payload data downlink
TET platform should be based on the BIRD satellite (maximum use of the BIRD heritage)
TET-1 Satellite mass: 120kg
Total Payload mass: 50kg

Derived from the above mentioned requirements and following a detailed mission analysis a mission scenario has been defined as shown in Fig. 1 below. The TET-1 satellite is launched as piggy-back in a LEO orbit. After LEOP and Commissioning the one year mission operation is controlled via the mission control centre in Oberpfaffenhofen. Payload data are stored in the payload data centre in Neustrelitz and can be retrieved from the Experimenters via secured web access.

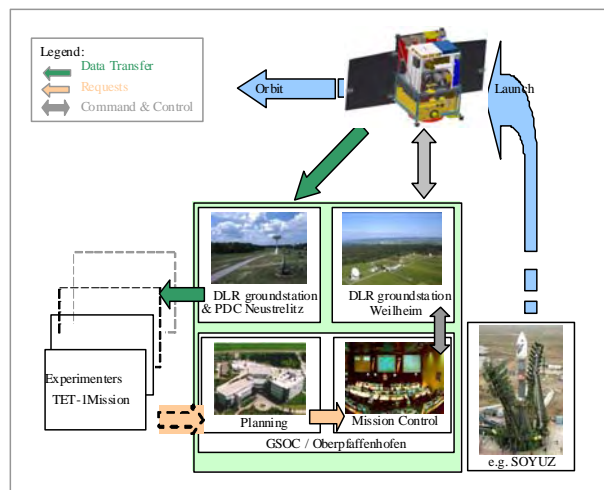

Figure 1: TET Mission Scenario

The essential conditions for operation of the payload are:

- Electrical power supplied by the satellite bus to the single experiment,
- Thermal power consumption of the payload impacts the overall thermal system,
- Pointing mode of the satellite,
- Data take/rate of the experiment limited by the mass memory.

A careful planning for the experiments is necessary to be compatible with these conditions. The following principle operational scenarios are foreseen:

- Standard weekly mission scenario: the TET payload is operated according to a schedule that is repeated after one week (approx. 15 orbits with approx. 100 minutes data downlink every day).
- Mission scenario 12: 12 times per year continuous experiments lasting 4 days are performed.
- Mission scenario 2: 2 times per year experiments with direct space-ground link is foreseen lasting 2 days.

These operating scenarios are commanded from the ground station and controlled by the Payload Supply System which is detailed in chapter 3.3.2.

The final decision concerning the piggy-back launcher is not jet made, but due to economical reasons a launch opportunity with SOYUZ/FREGAT from Baikonur is first choice. TET-1 is intended to be launched together with a Russian weather satellite METEOR-2. The adjoining picture shows a possible accommodation of TET-1 on SOYUZ/FREGAT. The final orbit is a sun-synchronous, 550km altitude, circular orbit. During launch the satellite is inactive and after separation from the launcher the satellite is activated.

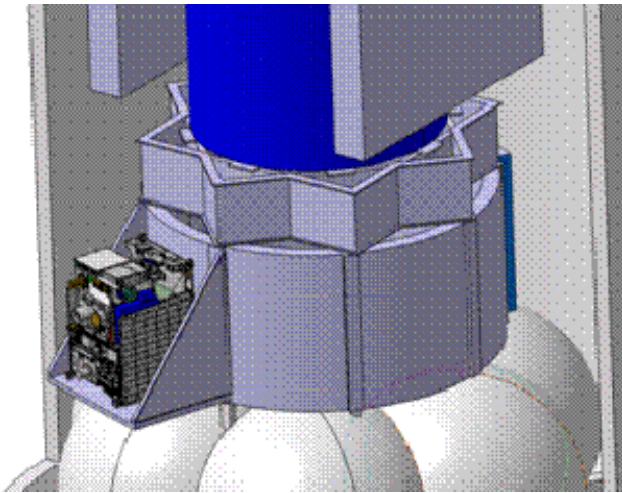

Figure 2: TET-1 Accommodation on launcher

The overall mission comprises the following mission phases.

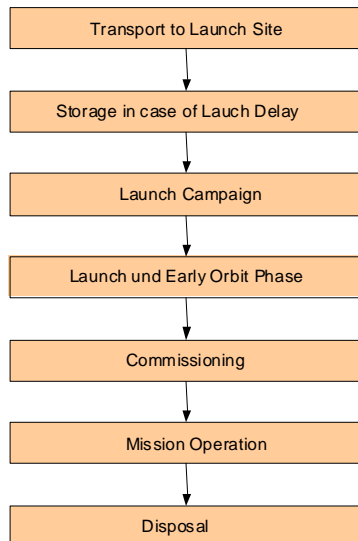

Figure 3: TET-1 mission phases

The main phases are described in more details:

- LEOP: The Launch and Early Operations Phase will last a few days and has the goal to ensure satellite survival after separation from the launcher. Solar arrays will be deployed; satellite attitude will be stabilized to allow battery charging by the solar arrays and initial housekeeping data will be acquired from the LEOP ground station network. LEOP will end when the satellite is in a stable situation with respect to power, attitude and communications.
- Bus and NVS commissioning: Components which were not activated in LEOP will be activated. All subsystems of the satellite bus and the NVS will be thoroughly tested.

- Operational mission: The operational mission will last 12 months. Payload commissioning and payload operations will be performed in this phase.
- End of operations (disposal): In this phase the payloads will be switched off and passivation measures will be performed for the bus and the payloads.

The TET-1 mission is structured as shown in Figure 4 and consists of three elements:

- the Space segment,
- the Ground segment and
- the Launch segment

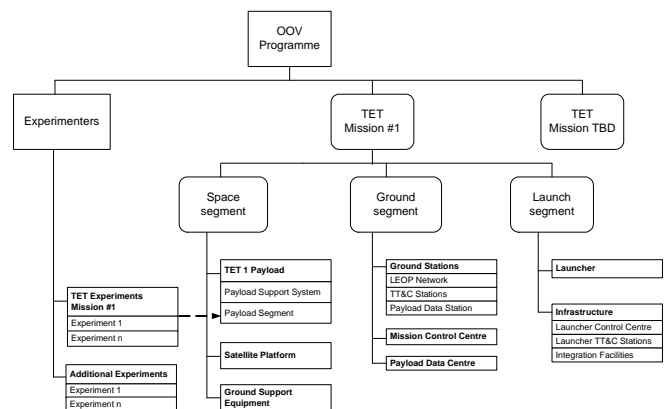

Figure 4: TET-1 Mission Elements

Each of these elements has been designed in past project phases and the results are shown in the forthcoming chapters.

3. SPACE SEGMENT

3.1. Overview

The TET-1 Space Segment consists of the Satellite Bus and the Payload. At an overall mass of about 118kg the Payload including the Payload Supply System and necessary support structures contributes with about 50kg. Fig. 5 below shows the Satellite Bus with integrated Payload in the launch configuration where the two solar panels on the left and right side are not deployed. The overall height of the Satellite is less than 880mm with a width of approximately 550mm and a depth of 650mm.

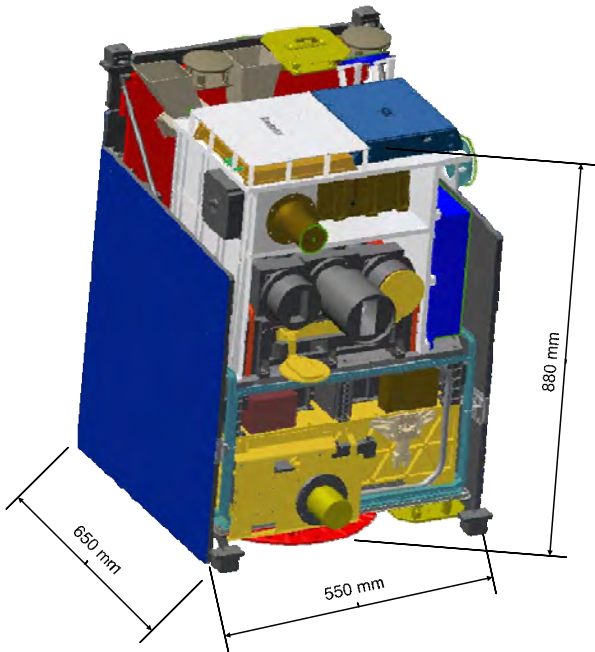

Figure 5 TET-1 Satellite (launch configuration)

In the deployed configuration as shown in Figure 6 below, the Payload Segment can be seen more clearly. It is located on top of the Satellite Bus main structure with the Payload Base Plate as the mechanical and thermal interface.

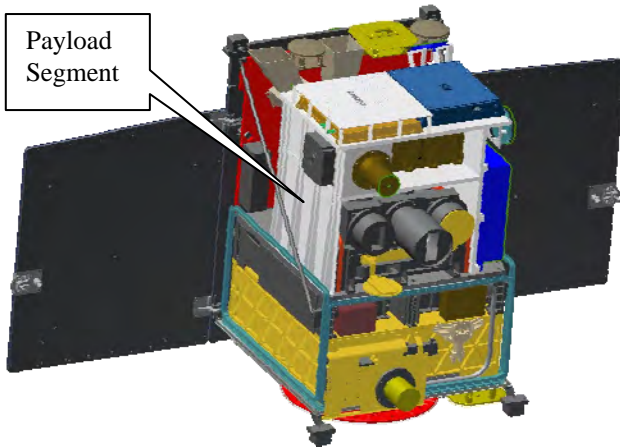

Figure 6: TET-1 Satellite (deployed configuration)

To limit the development time and to reduce the project risk the TET-1 satellite bus is based on the heritage of the BIRD satellite bus. The open satellite structure of the BIRD concept allows for a flexible payload accommodation which has been adapted for size and mass to fulfil the TET-1 needs.

11 experiments have been selected by DLR for this first TET mission. The experiments are developed by 11 different companies and institutions and comprise newest technology to be demonstrated for usage in space environment. The technical areas cover next generation solar arrays, navigation equipment, batteries,

cameras, communication equipment, and satellite propulsion system and computer hardware.

The Payload to Satellite Bus interface is realized and managed by a modular Payload Supply System developed by Kayser-Threde, allowing to be customized with minimum effort to the experiment needs and thereby reducing the effort for recurring missions.

Table 2: TET-1 Technical Data

TET-1 Technical Data	
Dimensions	: 880 mm x 550 mm x 650 mm (H x W x D) with about 90 liters of payload compartment
Mass	: Bus 70 kg : Payload 50 kg
Number of experiments	: 11
Stabilization	: 3-axes
Pointing accuracy	: 5 arcmin
Payload power consumption	: max 20W continuous
Uplink rate	: 4 kbit/s
Downlink rate	: 2.2 Mbit/s high rate
Orbit	: 550 km, SSO
Launch	: Mid 2010
Mission duration	: one year

3.2. Satellite Bus

The TET satellite bus can carry various adapted. It is a micro satellite bus based on the successfully employed micro satellite BIRD (Bi-spectral Infra-Red Detection).

On 22 October 2001 the micro satellite BIRD (Bi-spectral Infra-Red Detection) was launched successfully as secondary payload with the Indian rocket PSLV-C3 (Polar Satellite Launch Vehicle) into a circular sun-synchronous orbit of 572 km height. The satellite was designed, integrated and tested at DLR Berlin-Adlershof. The mission goal testing new small satellite technologies in space was accomplished as well as testing a new generation of infrared sensors combined with a modified WAOSS camera (Wide-Angle Optoelectronic Stereo Scanner). For the first time it was demonstrated that the expansion of vegetation fires and related flame temperatures can be detected with a special payload on a micro satellite. [1]

During the required life expectancy of 12 months all components worked correctly. For more than 80 months BIRD has been successfully sending data to earth.

In contrast to BIRD a higher payload total mass of 50 kg in a bigger dimension of $460 \times 460 \times 428 \text{ mm}^3$ is available for the payloads that should be verified. The Payload Segment contains, besides the experiments, satellite bus components which need a dimension of approx. $100 \times 275 \times 220 \text{ mm}^3$ for star cameras and $140 \times 55 \times 45 \text{ mm}^3$ for magnetic field sensors (Figure 7).

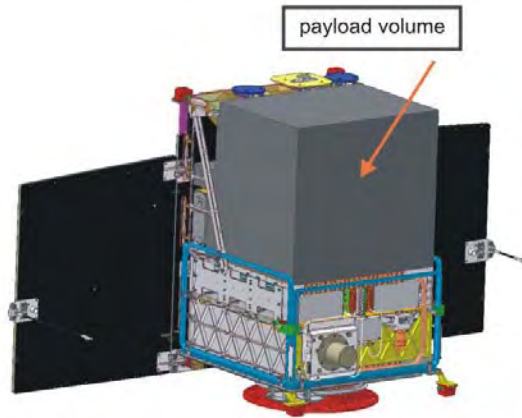

Figure 7: Available Payload Volume within TET-1

The satellite bus offers the possibility of fixing a payload panel above the central solar panel. Additional solar cells can also be installed on a special area on the central panel.

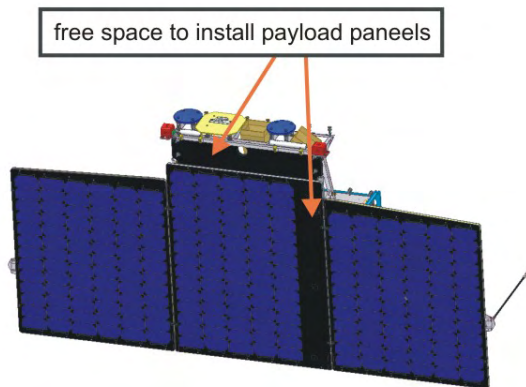

Figure 8: TET-1 Satellite Bus with Solar Cells and free space to install Payload Panels

Some other basic features of the TET satellite bus are the compact micro satellite structure with high mechanical stability and stiffness and a cubic shape in launch configuration with a dimension of $650 \times 550 \times 880 \text{ mm}^3$ (envelope) (see Figure 9).

The TET satellite bus relies on a passive thermal control system with radiators, heat pipes, MLI, temperature sensors and contingency heaters.

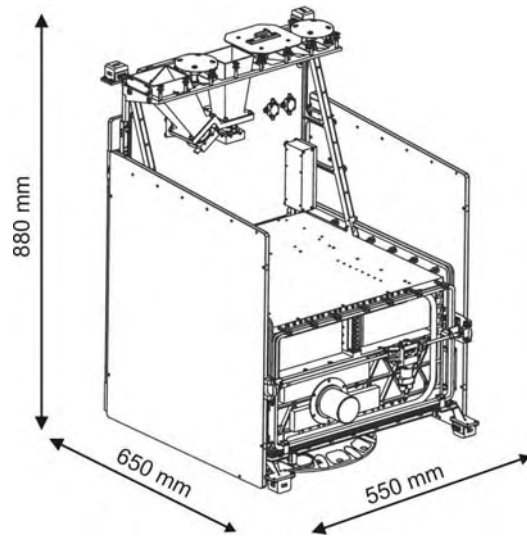

Figure 9: Envelope of TET Satellite Bus

The Power Subsystem consists of Power Control and Power Distribution Units, NiH_2 cell battery stacks including T-control and solar panels. The solar array consists of 3 panels; one fixed body mounted middle panel and 2 deployable side panels. The array is equipped with 246 solar cells (triple junction GaAs, efficiency 28%), with an electrical power of 220W (maximum power point). The capacity of the battery is 240Ah, energy transfer is done by DET (DirectEnergyTransfer).

The Spacecraft Bus Computer (SBC) controls all activities of the satellite bus. The SBC receives, stores and processes the commands, gathers and evaluates the housekeeping data of all subsystems and controls the telemetry. Furthermore it is also the attitude control computer of TET. The SBC consists of 4 identical SBC boards and watchdog circuits for failure detection and recovery. The architecture of the redundant SBC boards (nodes) is totally symmetric, that means, each of the boards is able to execute all control tasks. One node (the worker) is controlling the satellite while a second node (supervisor) is supervising the correct operation of the worker node. The two other node computers are spare components and are disconnected. If an anomaly of the worker node is detected by the supervisor node the supervisor substitutes the worker and takes over the control of the satellite. [2]

The Attitude and Orbit Control System (AOCS) consists of two star sensors, two gyroscopes, two magnetometers, 2 sets of sun sensors, 4 reaction wheels, a magnetic coil system. The attitude control system provides a high degree of autonomy basing on a state-space representation of the attitude estimation,

prediction and control, a real-time operation system embedding the attitude control software and a combination of the attitude control with an on-board navigation system (see Fig. 10 and 13).

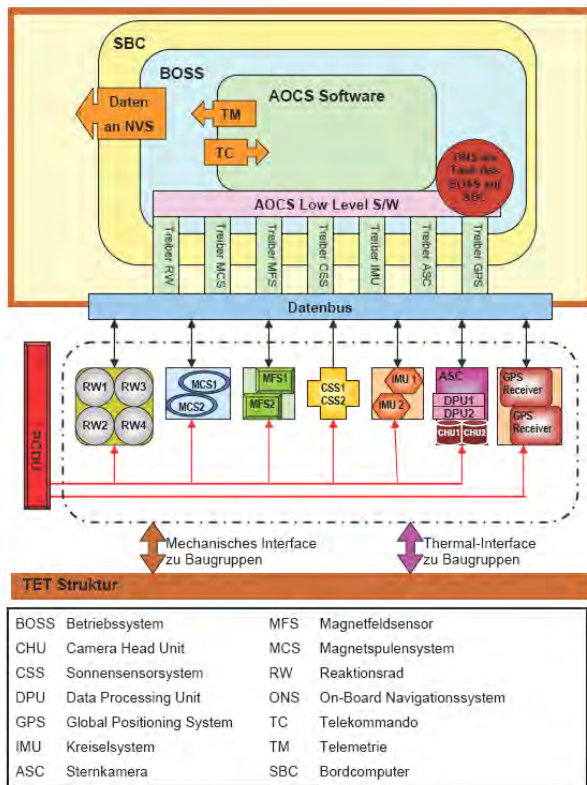

Figure 10: Scheme of the AOCS Interfaces

One of the most complicated tests during the verification process of the TET satellite bus is the testing of the Attitude and Orbit Control System. Software-in-the-loop simulations and hardware-in-the-loop simulations are well established test methods, but the best solution is real end-to-end test of the AOCS with a corresponding test facility. Based on the experiences with the BIRD AOCS test facility during the last years and the AOCS requirements, Astro- und Feinwerktechnik Adlershof GmbH has developed and built a new test facility for the end-to-end verification of the AOCS (see Fig. 11). [3]

The communication takes place using S-Band with high bit rate (2,2 Mbit/s) and low bit rate. The transmitter and receiver channels are redundant and can be switched to all antennas. (see Fig. 12).



Figure 11: Components of the TET Satellite Bus

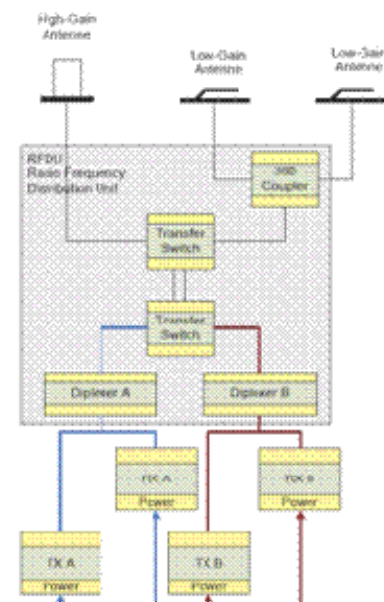

Figure 12: Scheme of the Communication System

The TET Satellite bus consists of three compact segments. In the service segment a battery, reaction wheels, the power control and distribution unit and laser gyro are installed. The Satellite Board Computer and the Payload Supply System are located in the electronics segment. The modifiable payload platform is the link between electronics segment and payload segment. In the payload segment are the experiments and also satellite bus components (star sensors, magnetic field sensors and antennas (low-gain and GPS) (see Figure 13).

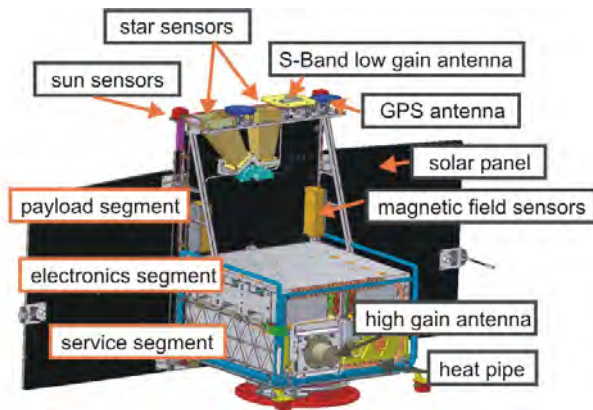

Figure 13: Components of the TET Satellite Bus

3.3. Payload

3.3.1. TET-1 Payload Segment incl. Experiments

As mentioned, 11 experiments are accommodated in the TET-1 satellite. The list of experiments is given below:

- three different types of next generation solar cells including thin-layer technology
- Lithium Polymer Battery
- two GPS receiver systems
- sensor bus system
- pico satellite propulsion system
- infrared camera as follow-up of the BIRD camera system
- Computer hardware
- RF communication system.

The accommodation of the experiments in the Payload Segment is shown on the following two figures. The accommodation has been driven by the various experiments needs as e.g. viewing directions, unobstructed view angles for antennas, heat dissipation, etc.

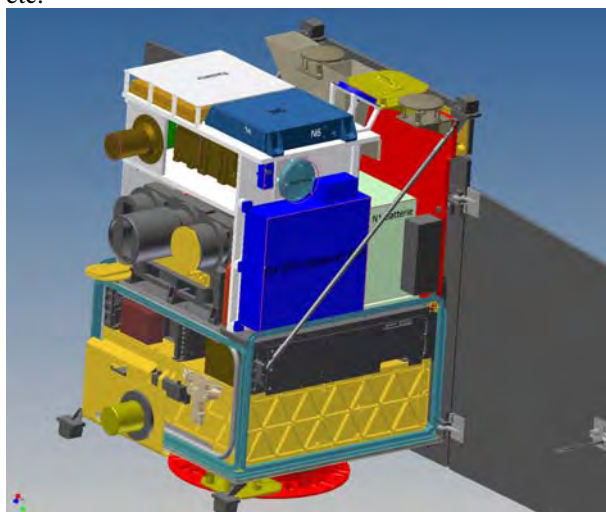

Figure 14: Accommodation of Experiments (1)

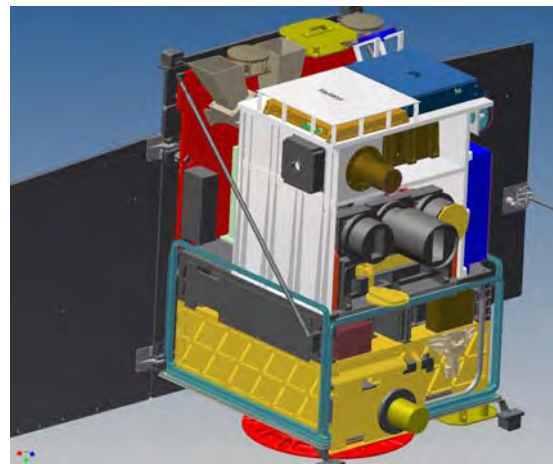

Figure 15: Accommodation of Experiments (2)

The solar cell experiments have been accommodated on the sun pointing side of TET-1 next to the Satellite Bus solar arrays, as shown in the next figure.

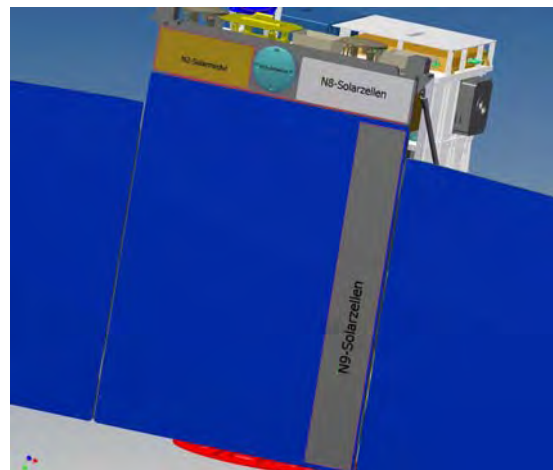

Figure 16: Accommodation of Solar cell Experiments

The TET-1 Payload configuration data is summarized in Tab. 4.

Table 3: Payload configuration data

TET-1 Payload Data	
Dimensions	: 428 mm x 460 mm x 460 mm (H x W x D)
Max. Payload Mass	: 50 kg incl. mass of Payload Supply System
Power consumption cont.	: 0 – 20 W incl. Payload Supply System
Power consumption max.	: 160W limited in time and occurrence
Supply Voltage	: 18 – 24VDC
Current max.	: 8A
TM Data Rate	: 2.2 Mbit/s max.
Storage	: 512 MByte
Heaters	: 0 to 15W

3.3.2 Payload Supply System

Via the Payload Supply System the interface between the Satellite Bus and the experiments is controlled. The Payload Supply System provides therefore a fixed part that interfaces to the Satellite Bus and a flexible part that can easily be adjusted to the experiments needs.

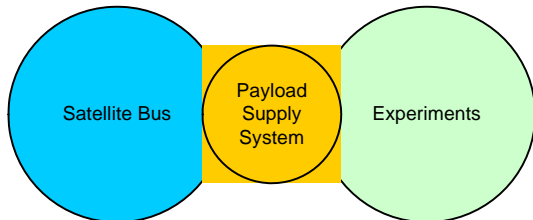

Figure 17: Payloads Supply System Interface

Based on this concept the Payload Supply System can be separated into three different parts:

- the power supplies responsible for the supply of the experiments and the Payload Supply System itself
- the processor boards that are used to control all Payload Supply System activities
- the I/O boards that provide the interfaces to the experiments.

All these parts will be realized on several printed circuit boards that will be connected via backplane. The experiments will be connected via front panel connectors.

The Payload Supply System is accommodated inside the Electronic Segment of the Satellite Bus next to the Satellite Bus Controller as shown in the figure below.

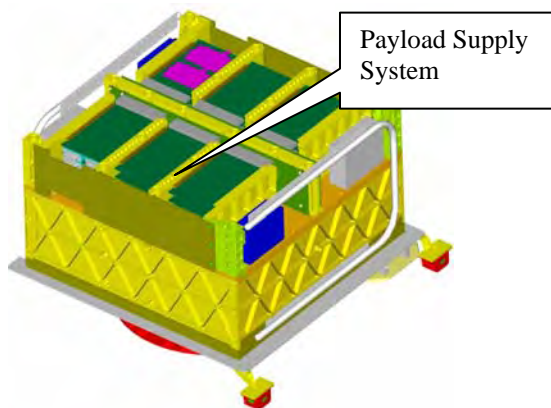

Figure 18: Accommodation of the Payloads Supply System

A block diagram of the Payload Supply System is shown in Fig. 19.

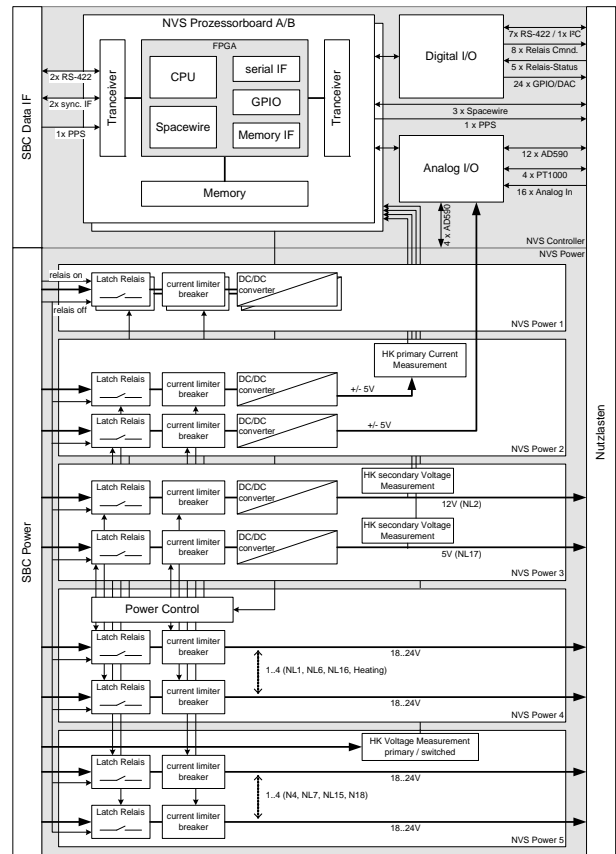

Figure 19: Payload Supply System Diagram

The functions provided by the software executed on the Payload Supply System processor cover the following tasks:

- control of experiments with minimal built-in processing logic
- acquisition of housekeeping data of the experiments and the Payload Supply System itself
- acquisition of measurement data of the experiments
- temporary storage of all acquired measurement and housekeeping data
- formatting and packaging of data according CCSDS for downlink
- reception and execution of commands from the Satellite Bus Controller
- Control of Payload Supply System devices as switches, circuit breakers, etc.
- management of thermal control of experiments and Payload Supply System
- Boot, self-test and software update management
- Failure Detection, Isolation and Recovery, redundancy management

Via the housekeeping sensors of the Payload Supply System the software controls the heaters installed in the Payload Segment to maintain the required temperatures for operating the experiments.

4. GROUND SEGMENT OVERVIEW

TET – Ground Segment Overview

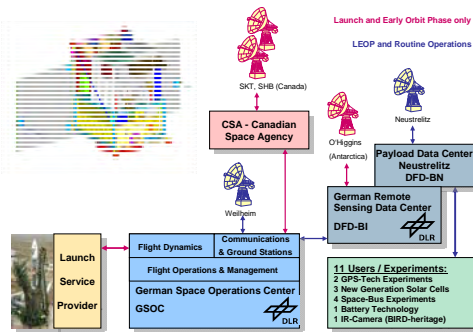

Figure 20: TET Ground-Segment Overview

Ground Segment project management, integration, test and training as well as all LEOP activities, routine mission operation and satellite control will be performed at the German Space Operations Center (GSOC).

Interfaces are established to the German Remote-Sensing Data Center (DLR-internal) and to external partners such as the launch-provider (data-exchange) and to the Canadian Space Agency (CSA) as provider of additional ground-station for LEOP-support. This is done on a co-operative basis (no exchange of funds), as DLR-GSOC supports Canadian missions with its resources.

DLR-owned S-Band ground stations in Weilheim, Neustrelitz and O’Higgins/Antarctica (for LEOP only) provide the necessary access to the satellite in all mission phases.

This ground station concept based mainly on DLR-owned resources is one of the reasons for cost-effective project design. However, operational requirements sometimes need to be tailored to the available uplink- and downlink resources.

A so called Payload Data Center (PDC) will be provided at the location of the data reception station in Neustrelitz. The main tasks are acquisition, extraction, processing (formatting to a generic ASCII format) archiving and provision of payload data.

The 11 users with their experiments onboard TET-1 retrieve (download) their data via a secure FTP interface. The main goals for the design and implementation process of the Ground Segment can be summarized as follows:

- Minimize number of project-specific systems and tools
- Make use of multi-mission core systems (Mission Data System, Flight Dynamics, networks,...)
- Use of multi-mission documentation and combining documents reasonably

- Efficient pooling of multi-project resources and personnel

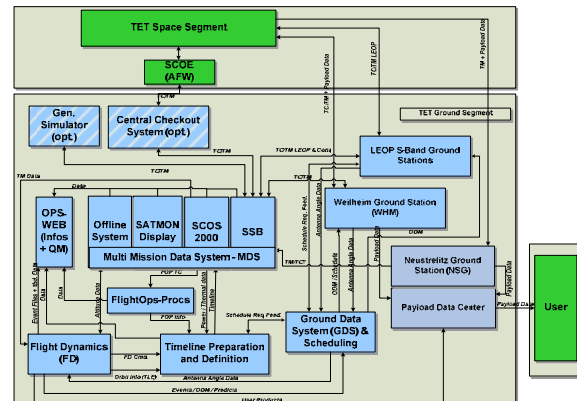

Figure 21: TET Ground Segment Functional Structure and Interfaces

Above figure illustrates the main functions of the ground-segment and their interfaces. The core element – the so-called Mission Data System (MDS) – is already fully operational and available and just needs to be configured for TET. The only exception being the Mission Information Base (MIB) which is specific for each project as it contains the definitions of TM and TC.

5. MISSION OPERATIONS

For the TET-1 mission the ground-segment will basically provide the execution of all necessary activities for a sound operation of the space segment and a continuous survey (Monitoring & Control) of functionality and integrity of all project elements. DLR-GSOC will perform this for all mission phases after launch for both the space segment and the ground segment.

During the mission preparation phase detailed analysis and planning of the mission operation will be undertaken and the operations processes will be designed, implemented, tested and validated. In the LEOP, bus commissioning- and routine operations phase telemetry data of the satellite and payload status is received and processed and telecommands for controlled changes of the satellite are sent. Onboard power and data storage availability, S/C attitude and payload requirements for previously scheduled payload events are compiled and executed.

In preparation for this, training sessions will be performed during project-phase D for all operations personnel at DLR/GSOC. The training comprises of class room and simulation sessions.

Due to the BIRD-heritage, the operational ground processes are already largely known to the experienced operations personnel at the control center GSOC and at the PDC in Neustrelitz.

TET – Ground Station Network and orbital injection

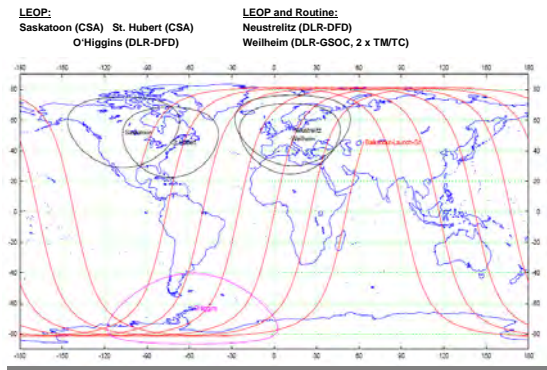

Figure 22: TET-1 Ground-Station Coverage and Orbit Tracks

After launch and successful orbit-injection and separation of TET from the launcher, GSOC is responsible for execution of early orbit operations. Above figure illustrates the first orbits after launch and the related coverage zones by the available ground-stations. LEOP is characterized as follows:

- Launch from Baikonour with Soyuz as secondary payload (“piggy-back”)
- Separation from Fregat upper-stage after injection in desired orbital altitude. Separation location is still TBD
- Spacecraft initiates automatic activation sequence and transits to safe-mode (attitude, power, thermal, communication)
- Initial acquisition of signal over DLRs O’Higgins (Antarctica) or Weilheim (Germany) ground-stations
- Begin of orbit determination process utilizing tracking data gained from the ground-station in Weilheim respectively from the external LEOP - support stations
- Start of checkout and ground-commanded configuration activities
- Support by 2 Canadian ground-stations begins after 4 orbits
- LEOP and bus commissioning duration: 7 days
- followed by activation of payloads and their checkout
- The routine mission operation and satellite control will be performed by GSOC engineering personnel during normal working hours with the support of a multi mission flight operations team (MMFS-team) responsible for shift operations as required. Three different pre-defined operational scenarios are identified to the present:

- General activities on a weekly basis,
- Additional activities during 4 days once per month,
- Specific activities during 2 days at start and end of mission.

Routine operation is characterized as follows:

- Ops-planning, health-monitoring and onboard maintenance at GSOC
- Upload of time-tagged executable commands to bus and payload: 3 days in advance, weekly cycle
- Commanding and TM-reception: once per day via Weilheim ground-station
- Upload of S/W and maintenance on request
- Download of data (payload and bus): 4 times per day
- Data reception and processing at Payload Data Center: automatic, 7 days a week

Operational tasks and responsibilities within the ground-segment during mission conduct:

- The DLR ground station in Weilheim will serve as main uplink (TC) and housekeeping telemetry reception (HK-TM) station.
- The DLR ground station in Neustrelitz will be used as main downlink station for payload data
- S-band data will be routed in real time from Weilheim and Neustrelitz to the Operations Center in Oberpfaffenhofen (GSOC) and all raw data will be stored at the receiving ground-stations for a limited period.
- Calibrated housekeeping data (i.e. uplink and downlink) will be archived at DLR/GSOC and can be used at GSOC for offline analysis, while payload data will be formatted to an additional generic ASCII format, provided and archived at Neustrelitz together with the raw instrument source packets and other auxiliary data products
- Mission control, preparation and execution of flight-operations, health-monitoring and performance analysis is performed at GSOC, as well as permanent orbit determination utilising
- GPS data and ‘station predicts’ will be generated to support acquisition of the satellite by the ground-stations.
- Initially, a dedicated control team consisting of engineers and spacecraft-operators will conduct LEOP and the initial commissioning phase (1-3 weeks, depending on mission progress).
- As soon as spacecraft and experiment activation and checkout are completed, all operations is transferred to the multi-mission environment – this refers to the control-facilities (consoles, control-room) as well as the operations concept (monitoring and control done by the Multi-Mission-Flight-Support-Team under offline and on-call supervision by engineers).

The above outlined operations concept for TET based on DLR-internal resources and on the multi-mission approach will make the most efficient use of the existing facilities, processes and teams as TET will be another mission added to the pool of presently 5 satellites permanently operated at GSOC.

6. SERVICES AND PRODUCTS

All users with experiments onboard TET-1 will be provided two payload data sets with different formats on a ftp-server. The Payload Data Centre (PDC) processes the received payload data during and immediately after data reception, which is planned 4 times a day.

The products (instrument source packets in raw binary form and as ASCII text file) will be made available at the ftp server 15 min after finishing data reception, secured by protected and selective access.

The format of both payload data products for all 11 users is identical, while contents differ of course.

The user additionally receives all auxiliary data (required for calibration purposes or additional processing) provided by GSOC via the same interface.

All data is stored on a permanent archive and a function for later retrieval is provided.

Table 4: TET Ground-Segment Data Products

Data Products	Content	Type	Availability	Remark
Auxiliary Data	- Ops-planning and as flown	tbd	Not restricted	
	- Orbit	tbd	Not restricted	
	- Attitude	tbd	Not restricted	
	- Bus-HK-data (including NVS)	ASCII	Not restricted	
	- Logs	ASCII	Not restricted	various
Payload Data	Raw Instrument Source Packets (ISP)	Binary	User Specific (pass-word protected access)	Generic format, but specific content for each user
	Converted File	ASCII	User Specific (pass-word protected access)	One generic format for all users, contents specific.

7. SUMMARY

The TET-1 mission is a national program funded from the German Space Agency. The TET program started with Phase A in January 2005, which ended October 2006. The TET-1 Phase B started in June 2007, followed by a successful SRR in August 2007 and was completed after the PDR beginning 2008. With Phase C/D Kick-off in May 2008 and the launch date mid of 2010 not only the satellite has to be ready within two years also the ground segment and the launch segment.

The goal of TET is the support of German industry and research institutes with the on-orbit verification of new and innovative satellite technologies. For this purpose

regular and reliable flight opportunities shall be offered, which can be realized on short notice. TET shall provide the required verification platform and shall be based on a satellite bus which was qualified on orbit during the BIRD mission.

The launch of the first satellite, TET-1, is scheduled for mid 2010. In total, eleven different payloads were selected to be demonstrated on TET-1. These include optical experiments such as an infrared camera as well as novel solar cells, batteries, on-board computers, GPS receivers and a propulsion system.

After the LEOP and commissioning phase, the one year mission operation will begin. Payload data will be transmitted to the TET ground segment and provided to the experimenters via the Payload Data Center.

8. REFERENCES

1. E. Lorenz and H. Jahn, BIRD: more than 3 years experience in orbit; Small satellites for Earth Observation, Selected Proceedings of the 5th International symposium of the International Academy of Astronomics, 102-109 (2005)
2. Sergio Montenegro and Felix Holzky: BOSS/EVERCONTROL OS/Middleware Target ultra high Dependability; DASIA2005, 30th May – 2nd June 2005 Edinburgh, Scotland
3. Z. Yoon, T. Terzibaschian, C. Raschke: Optimal Three-Axis Attitude Control Design, Simulation and Experimental Verification for Small Satellites Using Magnetic Actuators; Small Satellites Systems and Services - The 4S Symposium; 26-30 May 2008
4. S. Roemer, T. Terzibaschian, A. Wiener, W. Bärwald: Expertises with the BIRD ACS test facility and the resulting design of a state of the art mini- and micro-satellite ACS test facility; 6th IAA Symposium on Small Satellites for Earth Observation; 23th - 26th April 2007